



# TRILLIUM 120QA

## LOW-POWER VAULT SEISMOMETER

Nanometrics' commitment to investment in technology has led to an updated version of the proven Trillium 120QA Vault Seismometer. The latest generation Trillium 120QA maintains all of the performance and capabilities of the previous generation while reducing power consumption by over 50% as well as making it even smaller and lighter.

### Local, Regional & Teleseismic Studies

The Trillium 120QA is ideal for local, regional, and teleseismic studies having a response flat to velocity from 120 seconds to 150 Hz with exceptionally low self-noise. Operators will appreciate the low-power consumption, automatic mass centering, and robust no-mass lock design inherent in all Trillium seismometers.

### A Highly Integrated Station Solution

When using the T120QA with our popular Centaur digitizer, you'll have access to a digital leveling bubble through the Centaur GUI. The virtual leveling bubble makes for easy leveling in tight spaces and gives you the ability to check levelness at any time.

### Also Available:

Trillium 120 Borehole, Trillium 120 Posthole, Trillium 120 Slim Posthole, and Trillium Horizon for vault or shallow direct bury.



### Benefits:

- Ultra-low power consumption (230 mW)
- Robust aluminum pressure vessel designed for vault installations
- Ideal for regional and teleseismic studies
- Light weight and easy to deploy
- Automatic mass centering can be remotely initiated

# TECHNICAL SPECIFICATIONS TRILLIUM 120QA

Specifications subject to change without notice

## TECHNOLOGY

**Topology:** Symmetric triaxial

**Feedback:** Force balance with capacitive transducer

**Mass centering:** Automatic mechanical recentering, can be remotely initiated

## PERFORMANCE

**Self-noise:** See self-noise graph

**Nominal Sensitivity:**

- 1200 V/s/m (Standard Model)
- 2000 V/s/m (2000 V/s/m Model)

(reference User Guide for precise value), contact Nanometrics for other options

**Precision:** ±0.5% relative to User Guide specification

**Bandwidth:** -3 dB points at 120 s and 150 Hz

**Clip level:**

- 16.6 mm/s up to 10 Hz and 0.12 g above 10 Hz (Standard Model)
- 10.0 mm/s up to 20 Hz and 0.12 g above 10 Hz (2000 V/s/m Model)

**Dynamic Range:**

- 168 dB @ 1 Hz (Standard Model)
- 164 dB @ 1 Hz (2000 V/s/m Model)

**Temperature:** ±45°C without recentering

## POWER

**Supply Voltage:** 9 to 36 V DC isolated input

**Power Consumption:** 230 mW typical quiescent

**Protection:**

- Reverse-voltage and over-voltage protected
- Self-resetting over-current protection

## INTERFACE

**Connector:** 19-pin UTS7-14D19P32

**Velocity Output:** 40 V peak-to-peak differential

- Selectable XYZ or UVW mode

**Mass Position Output:** Three independent ±4 V outputs

**Calibration Input:** Single voltage input with one active-high control signal for all channels; calibration with XYZ or UVW

**Control Lines:** Mass Center, Calibration Enable, XYZ/UVW mode

**Serial Port:**

- RS-232 compatible serial IP (SLIP) with onboard HTTP web server to select sensor operating modes, and to access state-of-health, virtual level bubble, firmware updates and metadata
- Plug-and-Play automated workflow interface to select sensor operating modes, and to access state-of-health, virtual level bubble and metadata

## PHYSICAL

**Diameter:** 171.5 mm

**Height:** 175 mm, not including connector and feet

- 205 mm, including connector and feet

**Weight:** 5.3 kg

## LEVELING AND ALIGNMENT

**Bubble level:** Factory Installed

**Digital bubble level:** Graphical bullseye level is available via Centaur digital recorder GUI

**Digital tiltmeter:** Reports case tilt from vertical for easy installation and remote troubleshooting when using Centaur digital recorder

**Alignment:** North line on cover and vertical scribe marks for N and S on base

## ENVIRONMENTAL

**Operating Temperature:** -20°C to +60°C

**Storage Temperature:** -40°C to +70°C

**Optional:** Insulating cover available for best performance, with quick and convenient installation

**Humidity:** 0% to 100%

**Shock:**

- 20 g half sine, 5 ms without damage, 6 axes
  - no mass lock required for transport
- Ingress Protection:** Rated to IP68 and NEMA 6P to 2 m for prolonged immersion

## AVAILABLE MODELS

**T120-QA-SV2:** Standard Model

**T120-QA-SV2-2000:** 2000 V/s/m Model

## SELF-NOISE GRAPH

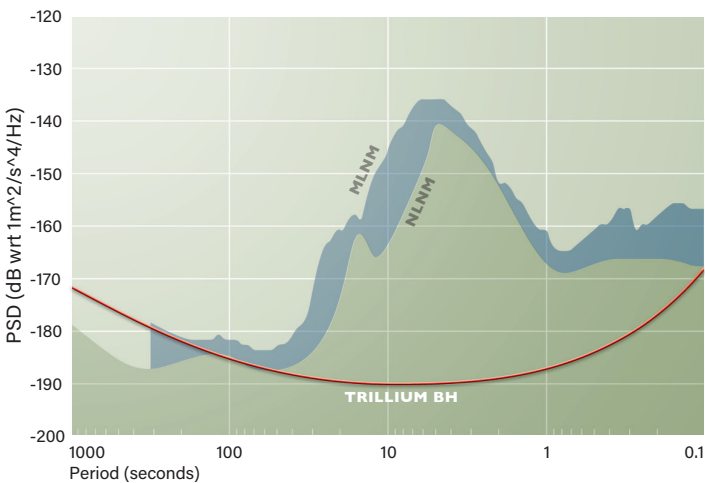

Seismometer self-noise plotted against NLNM (after Peterson, 1993) and MLNM (after McNamara and Buland, 2004)

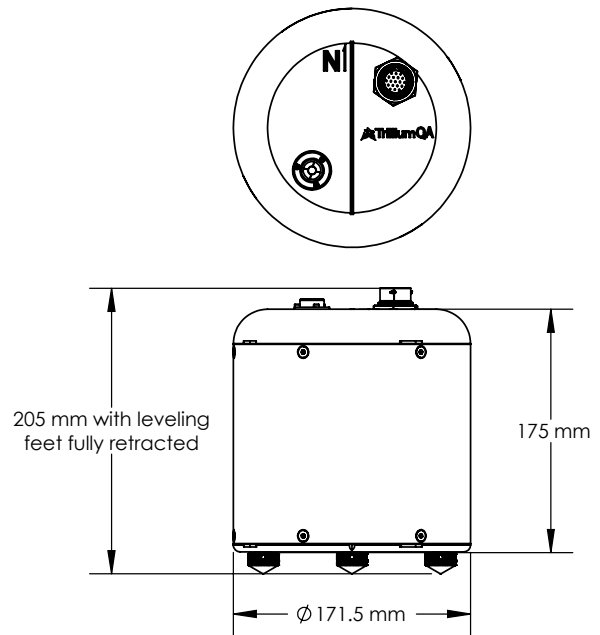

Contact a product expert Toll Free: 1 855 792 6776 | [sales\\_mkt@nanometrics.ca](mailto:sales_mkt@nanometrics.ca)



Listening to the Earth

3001 Solandt Road, Kanata, Ontario, Canada K2K 2M8 | Tel: +1 613 592 6776