



TRILLIUM COMPACT OBS

OCEAN BOTTOM SEISMOMETER

The **Trillium Compact Ocean Bottom Seismometer (OBS)** is an ultra-low power broadband seismometer for ocean bottom deployments to 6000 m depth. The OBS vessel and gimbal design preserves the full performance of the land-based Trillium Compact seismometer, including its exceptional dynamic range and low noise floor. For precise orientation, the integrated north finder capability automatically records the azimuth angle in the metadata.

Performance, Dependability and Availability

Incorporating a robust and reliable leveling gimbal that operates over a full 360° range, the Compact OBS will auto-level from all orientations. A full titanium cylindrical pressure vessel for 6000 m deployments, or aluminum-anodized enamel painted vessel for 1800 m deployments, and proven glass epoxy connectors ensure exceptional ruggedness and resistance to corrosion in marine and fresh water environments.

The system employs two separate connections: the primary analog connection as well as a digital connection. The primary analog connector is connected to the digital recorder during normal operation to capture the seismometer output, to actuate control lines, or to apply a calibration signal the digital connector is provided for final configuration and sensor verification prior to deploying the OBS overboard.

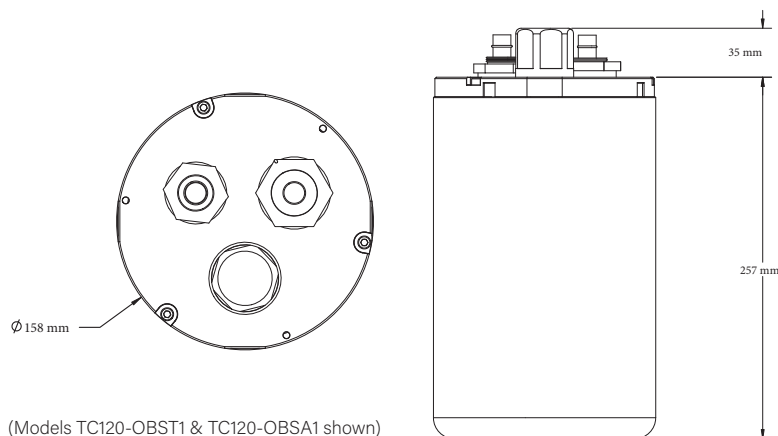

Benefits

- The integrated self-orienting north finder technology automatically determines and records azimuth in the metadata, which provides precise data analysis and more deployment flexibility.
- The precise, kinematic 360° gimbal auto-levels from any orientation ensuring successful deployment and implementation.
- Ultra-low 195 mW typical power consumption reduces battery costs.
- Exceptional dynamic range and low noise performance, regardless of landing angle.
- Compatible with Nanometrics' Abalones ocean bottom system and other OBS systems.
- Resilient to rough handling during deployment and recovery with no mass or gimbal lock required.

TECHNICAL SPECIFICATIONS TRILLIUM COMPACT OBS

*Specifications subject to change without notice

SEISMOMETER

TECHNOLOGY

Topology: Symmetric triaxial
Feedback: Force balance with capacitive transducer
Mass Centering: Not required

SEISMOMETER PERFORMANCE

Self-noise: See graph
Sensitivity: (Nominal) 750 V·s/m; (Actual) 754.3 V·s/m ±0.5%
Accuracy: ±0.5% relative to User Guide specification
Bandwidth: -3 dB points at 120 s and 100 Hz
Clip Level: 26 mm/s up to 10 Hz and 0.17 g above 10 Hz
Operational Tilt Range: ±2.5° without re-leveling
Parasitic Resonances: None below 100 Hz
Dynamic Range: 159 dB @ 1 Hz

AVAILABLE MODELS

TC120-OBST3: 6000 m, Titanium Model with Subconn Connector
TC120-OBST1: 6000 m, Titanium Model
TC120-OBSA1: 1800 m, Aluminum Model
TC120-OBSM1: Module, 360 degree Model
TC120-OBSM2: Module, 105 degree Model

LEVELING AND ORIENTATION

Gimbal Technology: Dual degree-of-freedom motorized gimbals

- Jam-free mechanism
- Kinematic design preserves full seismometer performance

Range: Levels in any orientation, full ±180° range
Accuracy: Levels to within ± 0.5° of true vertical
Leveling initiation:

Leveling checks done at some or all of:

- configurable delay after power on
- configurable periodic (three stage schedule)
- on external command
- Delay intervals configurable from seconds to months
- Levels only when needed based on configurable mass position threshold

NORTH FINDER CAPABILITY

Sensor Accuracy: ±0.5° for sufficient run time:

- 4 hours at 0° latitude
- 8 hours at 45° latitude
- 16 hours at 60° latitude

CONNECTORS/PLUGS

Main (Model TC120-OBST3):

- 16-pin submersible connector male, MCBH16MT1 (Titanium)
- Mounted on top of case

Main (Models TC120-OBST1 & TCBSA1):

12-pin female, VSK-12-BCL rubber-molded glass epoxy

- 40 V peak-to-peak differential seismic signal plus ground (3 channels)
- Serial RS-232 port (Rx,Tx)
- Calibration voltage input
- Power input and return

Auxiliary/diagnostic: 4-pin female, VSG-4-BCL rubber-molded glass epoxy

- Serial RS-232 port (Rx,Tx, Grd)
- Auxiliary control input

Vacuum/pressure port: 1/4-inch male quick disconnect with shutoff

- Vent for evacuation and servicing

PHYSICAL

Enclosure: Titanium (6000 m), or enamelled aluminum (1800 m)

- All connectors on end cap
- End cap removable for O-ring servicing
- Dual O-ring seals on end cap

Diameter: 158 mm
Height: 257 mm, not including connectors
Weight:

- 11.96 kg, 6.66 kg in sea water (titanium)
- 8.19 kg, 2.89 kg in sea water (aluminum)

Serial Port:

- RS-232 compatible serial IP (SLIP) with onboard web server standard HTTP to select sensor operating modes, and to access state-of-health, virtual level bubble, firmware updates and metadata
- Plug-and-Play automated workflow interface to select sensor operating modes, and to access state-of-health, virtual level bubble and metadata

POWER

Supply voltage: 9 to 29 VDC isolated
Power consumption: 195 mW typical (leveled, quiescent)
Protection: Reverse-voltage and over-voltage protected

- Self-resetting over-current protection
- Unit can be powered on for descent and ascent

ENVIRONMENTAL

Marine:

- Depth to 6000 m (titanium)
- Depth to 1800 m (aluminum)

Operating temp.: -20°C to +60°C
Storage temp.: -40°C to +70°C
Shock: 100 g half sine, 5 ms without damage, 6 axes

- No seismometer mass lock required prior to deployment and through full experiment cycle

Humidity: 0% to 100% (submersible)

DIGITAL COMMAND AND CONTROL INTERFACE

USER INTERFACE

Web browser: Onboard web server, accessed with industry standard web browsers using Serial Line IP (SLIP) HTTP
Plug-and-Play: Nanometrics for communication via Pegasus OBS Digital Recorder

CONFIGURATION AND CONTROL

Sensor: XYZ/UVW mode

- Calibration channel selection (off, all, U, V or W)
- Short/long period mode

Leveling: Initiate immediate leveling check

- Automatic cycle mode selection: (post power-on, three stage periodic)
- Automatic cycle parameter selection: (delay and interval times, max attempts)
- Unit:** Firmware updates
- State-of-health request
- Upload custom information

DATA OUTPUTS

On-request: Seismometer mass position values

- Temperature
- Internal relative humidity
- Magnetometer readings
- Seismometer response (poles, zeroes, sensitivity)
- Instrument serial number, subassembly revisions
- Firmware revision
- Case orientation (with respect to vertical)
- Seismometer orientation (with respect to vertical)
- Download logged state-of-health
- Erase state-of-health log
- Upload/Download custom information

Leveling Log: Every leveling event logged in non-volatile memory

- Full before-and-after State of Health logged

State of Health Log: Scheduled interval recordings of SoH, includes:

- time from power on
- seismometer mass positions
- vessel and seismometer orientations
- magnetometer readings
- temperature
- Capacity for >2 years daily recordings

SELF-NOISE GRAPH

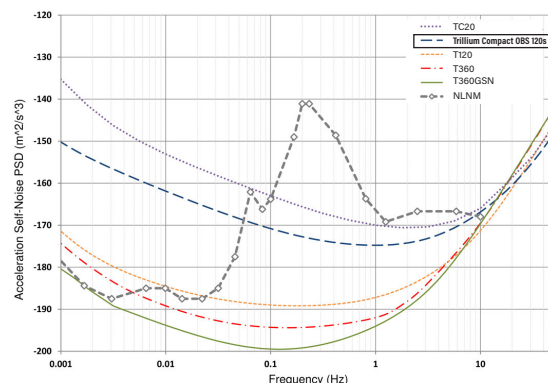

Seismometer self-noise plotted against NLNM (after Peterson, 1993) and MLNM (after McNamara and Buland, 2004)

Contact a product expert

Toll Free: 1 855 792 6776

sales_mkt@nanometrics.ca